

11 MEGA-PIXEL 8/10/12 BIT, 3 FPS, THERMOELECTRIC COOLED, FIELD UPGRADEABLE, PROGRAMMABLE DIGITAL CAMERA WITH CAMERA LINK OR GigE OUTPUT

IPX-11M5T-L
IPX-11M5T-V

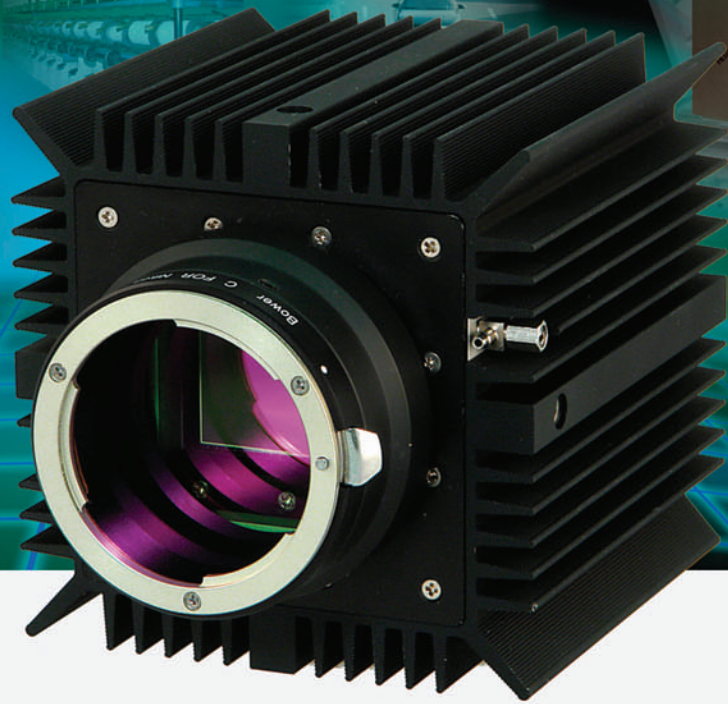

Features

- Single Stage Peltier Cooling
- Constant CCD temperature (optional)
- Optimized Thermal Equalization
- 4000 x 2672 pixels @ 5 fps
- Mono or Color, 8/10/12 bit data
- Base Camera Link or GigE output
- Single or Dual tap operation
- RS232 serial communication
- 32 bit RISC processor
- Horizontal and vertical binning
- Highly programmable:
 - resolution • frame rate
 - electronic shutter • long integration
 - external trigger • pre-exposure
 - fast triggering • double exposure
 - strobe output • gain and offset
 - area of interest • user LUT
- Dynamic Black Level Compensation
- Dynamic Transfer Function correction
- Temperature monitor
- Field upgradeable
- Flat Field Correction
- Defective Pixel Correction

Applications

- Flat Panel Display Inspection
- Machine Vision and Metrology
- Scientific Imaging
- Medical Imaging
- Microscopy



FAST...SMART...FLEXIBLE...
LYNX FAMILY

The **IPX-11M5T-L/V** is an advanced, high-resolution progressive scan, fully programmable and field upgradeable CCD camera, built around KODAK's KAI-11002 interline transfer CCD. The camera provides 4000 x 2672 resolution and delivers 5 frames per second at full resolution. The camera image processing engine is based on a 2 million gate FPGA and 32 bit RISC processor, featuring programmable resolution, AOI, binning, triggering, shutter, long integration, transfer function correction and user LUT. Support for DPC and FFC.

Specifications for IPX-11M5T-L/V

Active Image Pixels	4000 (H) x 2672 (V), Mono or Color
Active Image Area	36.07 mm x 24.05 mm
Pixel size	9.0 um
Video Output	Digital, 8/10/12 bit, one or two outputs
Camera Interface	Base Camera Link or GigE
Data Clock	28.000 MHz
Resolution	4000 x 2672 pixels max
Frame Rate	5 fps (dual) / 2.5 fps (single), up to 49 fps w/AOI
Shutter Speed	1/10000 sec to 1/3 sec
Long Integration	1/3 sec to 10 sec
Gamma Correction	G=1.0, G=0.45, User defined LUT
Black Level Offset	256 levels/output
Video Gain	6-40 dB, 1024 steps/output
External Trigger	Asynchronous
Hardware Trigger	External, level sensitive, 3.3V - 5.0V, 10 mA., Active HIGH/LOW, programmable exposure
Software Trigger	Internal (GigE) or CC1, exposure control
S/N Ratio	66 dB
Strobe Output	Active HIGH, for external light source
Lens Mount	F mount, 43.3 mm image diagonal
Environmental	Operating: -5 to 50 C, Storage: -10 to 65 C
Min. Illumination	1.0 Lux, f=1.4, no IR cut filter, no shutter
Mechanical	(100 x 100 x 100) mm; 1350 g (48 oz)
CCD Cooling	Single Stage Peltier Thermoelectric cooling
CCD Temperature	5 C below ambient - natural convection (default) 15 C below ambient - forced air (fan)

Power Connector

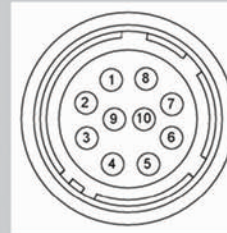

Rear View CL

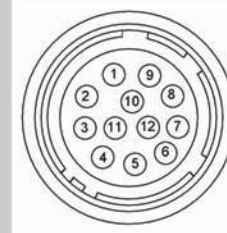

Rear View GigE

- 1 Trigger IN -
- 2 Trigger IN +
- 3 -12 VDC
- 4 -12 VDC
- 5 +12 VDC
- 6 +12 VDC
- 7 Strobe OUT -
- 8 Strobe OUT +
- 9 Auto Iris +
- 10 Auto Iris -

- 1 -12V DC
- 2 +12V DC
- 3 Auto Iris 1
- 4 Auto Iris 2
- 5 Auto Iris GND
- 6 Strobe GND
- 7 Strobe OUT
- 8 Trigger IN
- 9 N/C
- 10 Trigger GND
- 11 N/C
- 12 N/C

Power Requirements

- 12V DC, (10V min, 15V max)
- LYNX: 1.15A 13.8W
- GigE: 1.30A 15.6W
2.50A inrush

Mechanical Dimensions

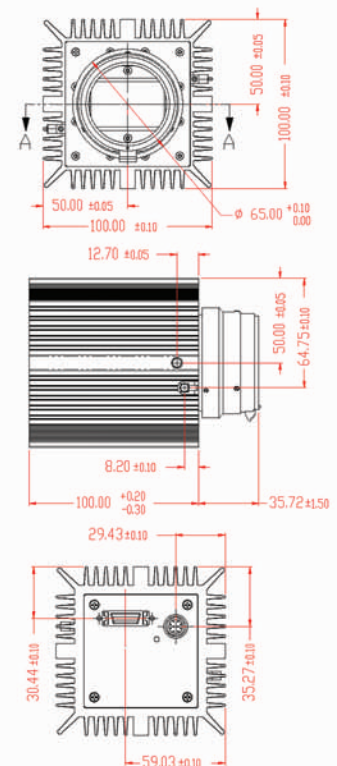

Spectral Response

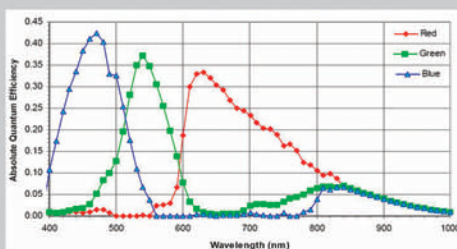
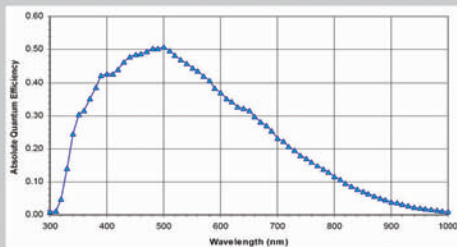

Ordering: **IPX-11M5T-LMFB**

Camera Family

- L** - LYNX Camera Link
- V** - LYNX GigE Vision

Sensor Type

- M** - Monochrome
- C** - Color
- U** - UV sensitive (no glass)

Options

blank - none

Lens Mount

F - "F" mount (default)

Configuration Utility

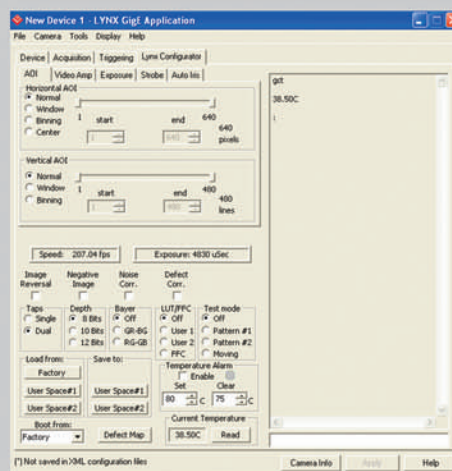

- CameraLink protocol compliant, or
- GigE Vision with Gen < i > Cam protocol compliant
- Camera configuration utility for CL
- Integrated software tools for GigE
 - data acquisition and display
 - camera control and communication
 - camera configuration utility

For specific details and ordering information, consult the camera user's manual or contact us at sales@imperx.com.

Copyright © 2004, Imperx, Inc. Product information subject to change without notice.

Rev. 1.0, 03/20/07



Imperx Incorporated • 6421 Congress Avenue • Boca Raton, FL 33487 • USA
 Phone: 1-561-989-0006 • 1-866-849-1662 • Fax: 1-561-989-0045
 www.imperx.com • sales@imperx.com

Made in USA

