

Quick Start

POWER SUPPLY

PS12V17A

**for use with Cheetah Python GigE Vision[®], USB3, and
10 GigE Vision[®] cameras having Canon EF lens control**

Imperx, Inc.
Tel: (+1) 561-989-0006
Fax: (+1) 561-989-0045
Email: support@imperx.com
Web: www.imperx.com

Copyright © 2021 Imperx, Inc. All rights reserved.
Any unauthorized use, duplication or distribution of this document or any part thereof, without the prior written consent of Imperx Corporation is strictly prohibited.

WARRANTY

Imperx, Inc. warrants that this product will be free from defects in materials and workmanship for (2) years from date of purchase.

Introduction

Imperx advanced digital cameras require an external 12 V DC power supply to provide power for camera operations, communications, and control. While users are free to provide their own source of camera power, Imperx recommends using the Imperx power supply for best performance.

The PS12V17A power supply provides +12 V DC $\pm 5\%$ and up to 3 A DC current to the Imperx Cheetah GigE Vision[®], USB3, and 10 GigE Vision[®] cameras with Canon EF lens control. The operating input voltage range is from 100 to 240 V AC.

The PS12V17A power supply is compatible with the following Imperx cameras having Canon lens control:

Item	Description	Compatible with
PS12V17A	12 V DC, 3 A, With one strobe and one trigger, Canon EF lens connector, 12-pin Hirose	GEV/U3V/10G-C4181 and GEV/U3V/10G-C5180 with Canon EF lens control

PS12V17A Power Supply

The PS12V17A power supply is comprised of three components:

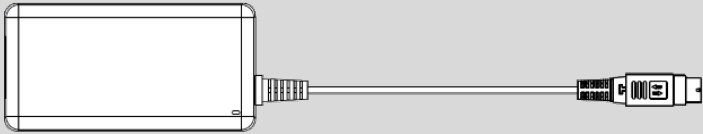
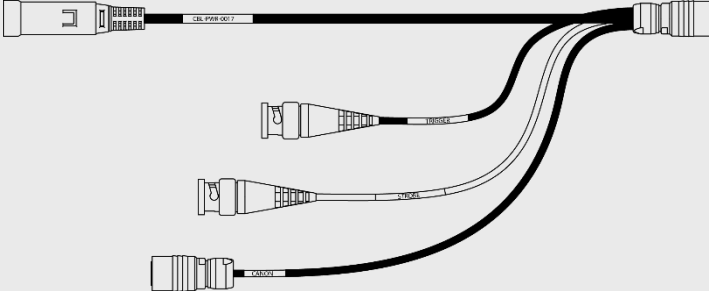
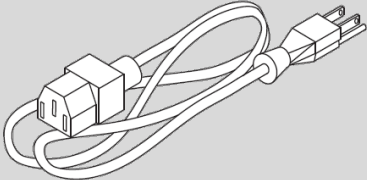
Item	Part number	Qty.	
Universal Power Supply	PS12V10	1	
I/O and Power Cable	CBL-PWR-0017	1	
Power Cord	-	1	

The CBL-PWR-0017 cable terminates in a female Hirose type miniature locking plug #HR10A-10P-12S(73). It has two BNC pig-tail cables providing external trigger input (black) and strobe output (white). It also features a cable providing lens control interface and lens power through a 6-pin female Sam Woo plug.

PS12V17A Technical Drawing

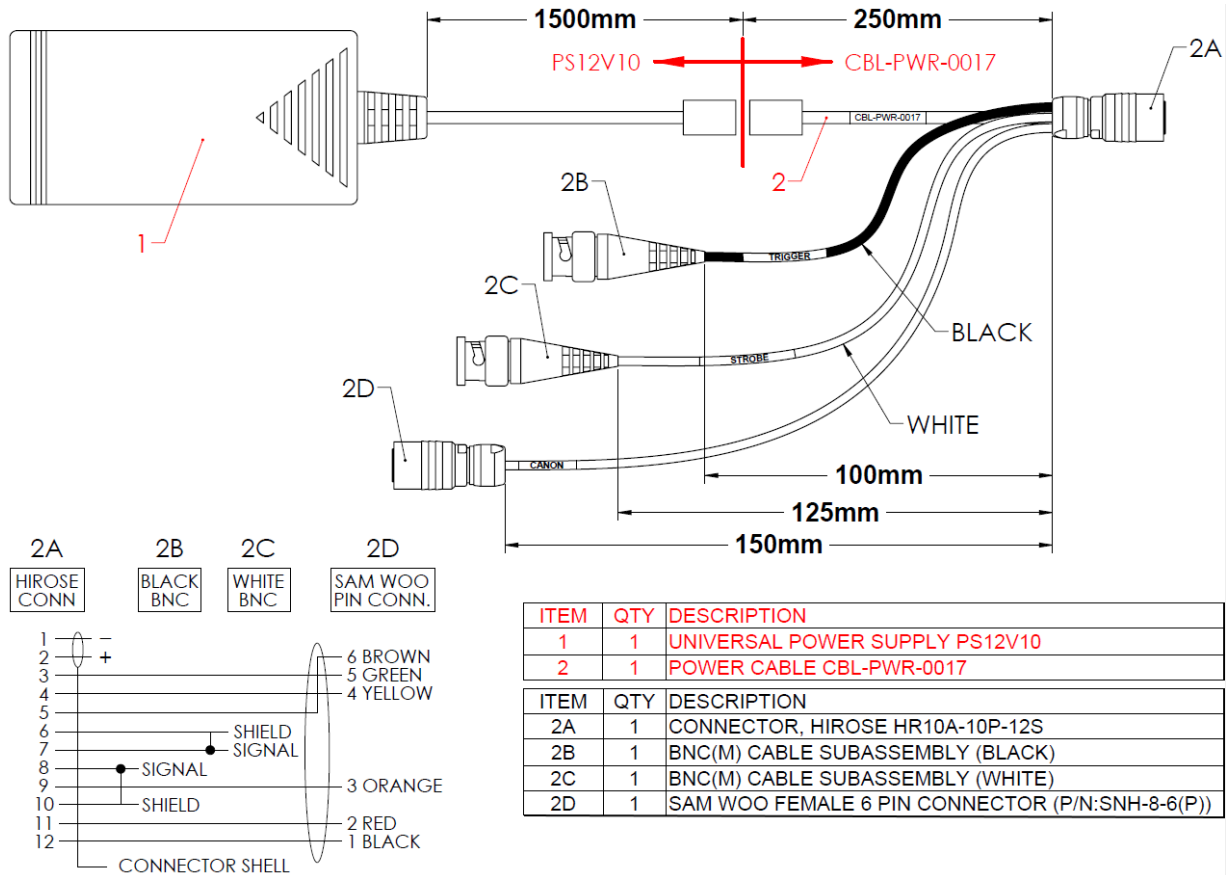

Hirose Pin Assignment

Pin	Signal Name	Use
1	+12 V DC RTN	12 VDC Main Power Return
2	+12 V DC	12 VDC Main Power
3	DLC	Canon Lens: Data from the lens to the camera
4	DCL	Canon Lens: Data from the camera to the lens
5	LCLK	Canon Lens: Clock
6	OUT1 RTN	General Purpose Output 1 Return (TTL)
7	OUT1	General Purpose Output 1 (TTL)
8	IN1	General Purpose Input 1 (Opto-isolated)
9	+5 V	Canon Lens: Logic Circuitry Power
10	IN1 RTN	General Purpose Input 1 Return (Opto-isolated)
11	+6 V	Canon Lens: Motor Power
12	GND	Ground

Connecting the Power Supply

The power supply uses KYCON connectors with a snap-and-lock feature that helps prevent accidental disconnects. Follow the steps below to connect the power supply to a camera.

1. Connect a power cord to the PS12V10 power adapter.
2. Connect the KPPX-4P plug of the PS12V10 Power Adapter to the KPJX-CM-4S socket of the CBL-PWR-0017 cable.

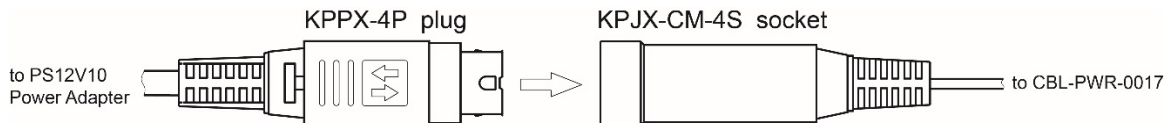

CAUTION

Push connectors together until the locking mechanism clicks, and there is no gap between the connectors. If connection is not secure, overheating may occur leading to the cable damage or fire.

Correct position

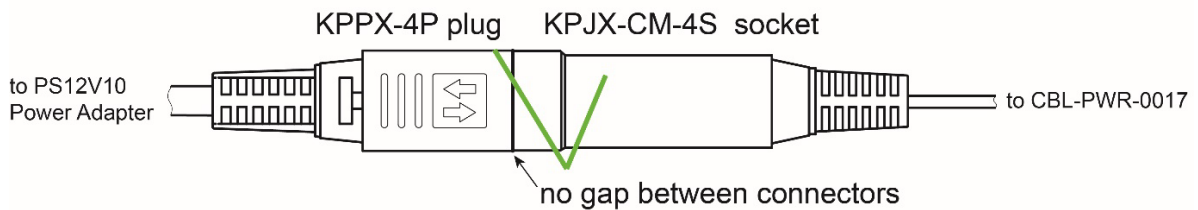

Incorrect position

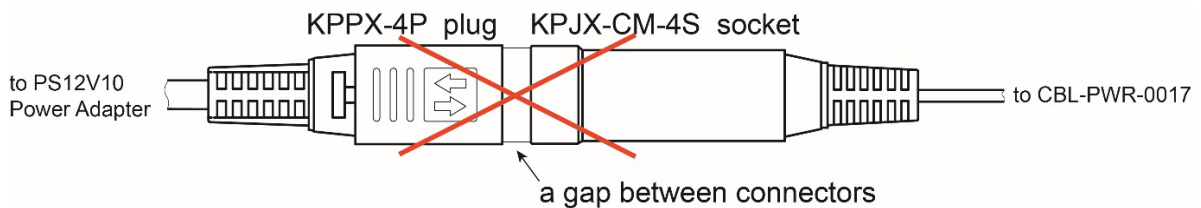

3. Connect the other end of the CBL-PWR-0017 cable to the IMPERX camera.
4. Connect the Sam Woo connector to the Imperx Canon EF lens mount.
5. If applicable, connect Trigger and/or Strobe cables to external devices.

CAUTION

When disconnecting the I/O cable from the PS12V10 power adapter, pull on the plug. Do not pull on the cable. Doing so may result in damage to the cable.

PS12V17A Power Supply Connection Diagram

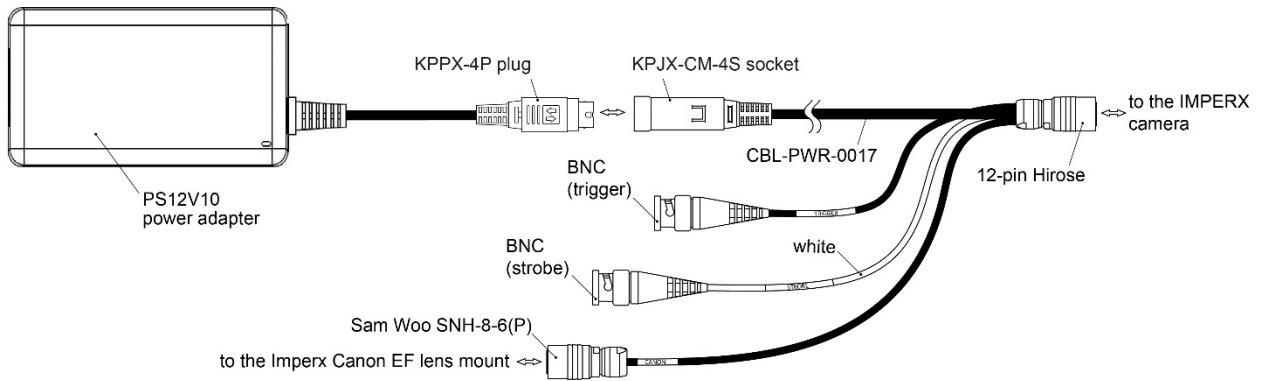

Power Supply Specifications

Specifications	Description
Input	
Voltage	100–240 V AC
Frequency	50–60 Hz
Current	1 A max
Inrush Current	70 A max / 230 V AC (cold start @ 25 °C, full load)
Efficiency	Eff (av) ≥ 87.4 % (at 115 V AC & 230 V AC) Eff ≥ 78.303 % (at 230V/50Hz input @10% load for CoC Tier2)
Output	
Voltage	11.4 V to 12.6 V DC, 12 V DC nominal
Current	3 A max
Load Regulation	± 5%
Ripple & Noise	1% Vpp max for Output Voltage @ full load
Total Power	36 W Max
Protection	
Over-Voltage Protective (OVP)	V out * 180% (max)
Short-Circuit Protective (SCP)	Automatic recovery after short circuit fault being removed
Over Current Protection (OCP)	I out * 200% (max)
Safety, EMI and EMC Requirement	
Safety	UL, CUL, GS, PSE, BSMI, CB, RCM, CCC, KC, LPS
Dielectric Strength	10 mA max. cut off current (1) Primary to Secondary: 3000 V AC for 1 minute (2) Primary to Frame Ground: 1500 V AC for 1 minute
Insulation Resistance	(1) Primary to Secondary: 10 MOhm for 500 V DC (2) Primary to Frame Ground: 10 MOhm for 500 V DC
EMI Requirement	CE, FCC Class B, Conduction and Radiation meet
Leakage Current	Less than 3.5 mA
Grounding Test	Resistance 0.1 Ohm max @ 32 A
Environmental	Operating: 0 °C to +40 °C Storage: -20 °C to +80 °C
Relative humidity	Operating: 20% to 80% non-condensing Storage: 10% to 90% non-condensing
Regulatory	DoE VI, ErP (Lot 7), GEMS, NRCAN, CEC, RoHS
Cable Length	
Supplied AC power input cable (IEC)	1.8 m (6')
Power supply output (+12 V)	1.75 m (5') ± 15 cm (6"), connector HIROSE #HR10A-10P-12S
Strobe	12.5 cm (5") ± 1 cm (0.4") connector BNC male
Trigger	10 cm (4") ± 1 cm (0.4") connector BNC male
Canon	15 cm (5.9") ± 1 cm (0.4")